

# INSTRUCCIONES DE ENSAMBLE /ASSEMBLY INSTRUCTIONS

## MUEBLE ALUVIA 40 X 35

/ ALUVIA 40 X 35 VANITY

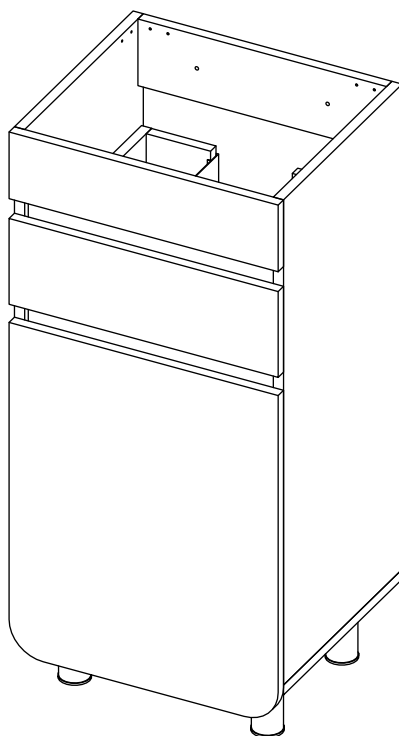

Alto: 85 cm  
Ancho: 39.5 cm  
Fondo: 34.5 cm

LOTE No: \_\_\_\_\_

### BAÑOS Y COCINAS



Línea de atención

Bogotá: 404 88 84

Colombia: 01 8000 51 20 30

Otros países: +57 (1) 404 88 84

Customer service

+57 (1) 404 88 84

**corona.CO**

**corona**

corona

# BAÑOS Y COCINAS

“Lea muy bien el instructivo antes de armar el producto, ármelo en un lugar limpio y preferiblemente en una superficie plana”



## RECOMENDACIONES IMPORTANTES KEY RECOMMENDATIONS



NO pinte el mueble /  
Don't paint the  
furniture.



NO ubicar a la intemperie /  
Don't expose to rain  
or direct sun.

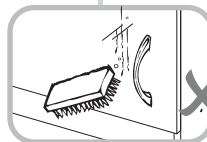
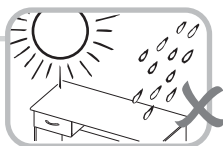

NO lavar las manijas o  
tiraderas con jabones o  
elementos abrasivos /  
Don't wash handles  
or dumbs with soap or  
abrasives.

NO mojar o evitar chorro  
de agua directo, en tal caso  
secar con un trapo /  
Don't wet or avoid splash  
water directly, in such  
case wipe dry.

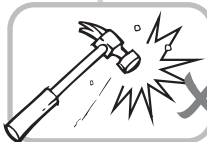
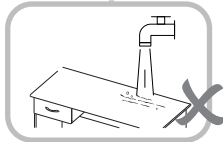

NO golpear ni martillar  
el mueble (hágalo sólo  
donde se indique) /  
Don't hit or hammer  
the furniture (just do it  
where indicated).

NO sobrecargue el mueble.  
no exceda el peso de 30 kilos  
para gabinetes de cocina /  
Don't overload the cabinet.  
Weight not exceeding 66LB  
for kitchen cabinets.



SIEMPRE levante el mueble  
entre dos personas, NO lo  
arrastre / Don't drag the  
furniture. Lift it between  
two people.

NO permita que los niños  
manipulen el mueble, puede  
voltearse y lastimarlos /  
Don't allow children to handle  
the cabinets or drawers.

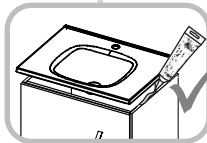

SE RECOMIENDA aplicar  
silicona en el empalme entre  
el lavamanos y el mueble para  
evitar filtraciones de agua /  
To avoid water leaks it is  
recommended to apply  
silicone between the cabinet  
and the sink.

Limpie con paño seco y  
lustrador de muebles,  
de esta forma alarga la  
vida del mueble / Clean with  
a dry cloth. Polishing wax for  
furniture can be use.



## RECOMENDACIONES DE ENSAMBLE

De un adecuado armado del mueble depende su buen funcionamiento.  
Following the cabinet assemble instructions will assure its proper functioning.

### MINIFIX

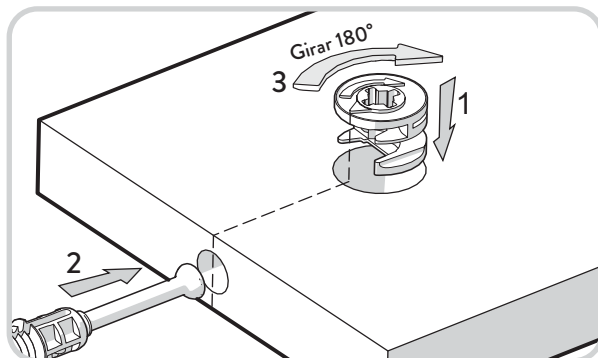

### TARUGOS



**GARANTÍA:** Este mueble para baño CORONA® tienen una *garantía de 1 año* en partes de madera y en herrajes, a partir de la fecha de compra.

La garantía cubre defectos de fabricación y mala calidad de materiales que impidan el armado y uso del mueble. Dado el caso se reemplazará la(s) pieza(s) defectuosa(s). El tablero melamínico no se despega siempre y cuando cumpla estrictamente las recomendaciones sobre el cuidado del producto. Estos están inmunizados.

Examine completamente las piezas antes de ensamblar, una vez armado el mueble, la empresa NO se hará responsable por piezas dañadas. La garantía NO aplica para productos que hayan sido armados incorrectamente, manipulados o utilizados de manera no razonable, modificados, reparados, o que hayan sido sobrecargados o expuestos a chorro de agua directa o hayan omitido alguna de las recomendaciones establecidas. No incluye mano de obra para el ensamble del mueble. Esta garantía aplica únicamente bajo condiciones normales de uso y manipulación.

Para hacer válida la garantía, comuníquese con nuestra línea de atención al cliente de CORONA.



Línea de atención

Bogotá: 404 88 84

Colombia: 01 8000 51 20 30

Otros países: +57 (1) 404 88 84

Customer service

+57 (1) 404 88 84



Garantía  
Corona  
1 Año

corona.CO

# HERRAJES PARA ARMADO

## ASSEMBLY HARDWARE

x31



Tarugo/  
Fluted dowel pin

x25

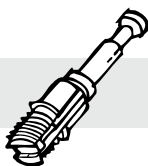

Perno minifix/  
Spreading bolt

x25



Minifix/  
Minifix connector

x20



Tapa adhesiva  
color 1/  
Cover Caps

x5



Tapa adhesiva  
color 2/  
Cover Caps

x4



Soporte entrepaño/  
Shelf support

x4



Tornillo de  
Ensamble 2"/  
Drywall Screw  
2"

x2

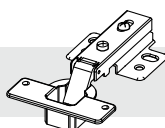

Bisagra Parche  
Slide On/  
Full Overlay hinge

x1

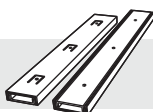

Riel Extensión  
Total 25 cm/  
Full Extension Drawer Slides

x1

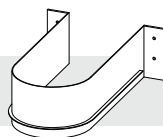

Pieza plástica  
en U pequeña/  
Plastic U accessory  
small size

x2



Tope burbuja/  
Bum Pum Stop

x48



Tornillo lámina/  
Sheet Metal screw

x4



Pata acero/  
Steel leg

x2

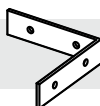

Platina en L/  
Angle Brackets

x2



Chazo Mariposa/  
Taquete+ Tornillo  
ensamble 2" 1/2  
/ Plastic wall anchor



### IMPORTANTE

TENER PRECAUCIÓN AL ABRIR LA BOLSA DE HERRAJES PARA NO EXTRAVIAR NINGUNO. COMPRUEBE QUE EL CONTENIDO DE LAS PIEZAS SEA EL CORRECTO. EN CASO QUE FALTE ALGUNA PIEZA O ESTE DEFECTUOSA LE AGRADECEMOS LLAMAR DE INMEDIATO A LA LÍNEA DE ATENCIÓN EN COLOMBIA: 01 8000 51 20 30 -BOGOTÁ: 404-88 84 - PARA OTROS PAÍSES: + 57 (1) 404 88 84 - SERVICIO AL CLIENTE: + 57 (1) 404 88 84

# CARGAS MÁXIMAS SUGERIDAS

## MAX SUGGESTED LOADS

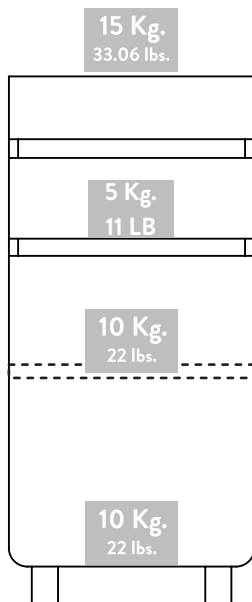

## PIEZAS DE ARMADO

### ASSEMBLY PARTS

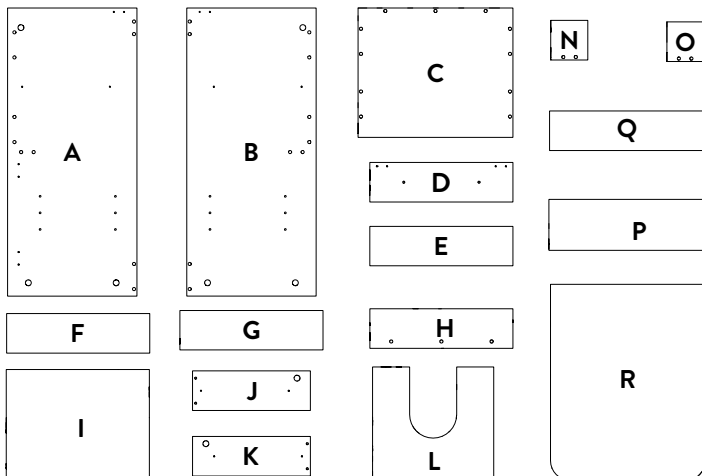

**IMPORTANTE**

TENER PRECAUCIÓN AL ABRIR LA BOLSA DE HERRAJES PARA NO EXTRAVIAR NINGUNO. COMPRUEBE QUE EL CONTENIDO DE LAS PIEZAS SEA EL CORRECTO. EN CASO QUE FALTE ALGUNA PIEZA O ESTE DEFECTUOSA LE AGRADECEREMOS LLAMAR DE INMEDIATO A LA LÍNEA DE ATENCIÓN EN COLOMBIA: 01 8000 51 20 30 -BOGOTÁ: 404-88 84 - PARA OTROS PAÍSES: + 57 (1) 404 88 84 - SERVICIO AL CLIENTE: + 57 (1) 404 88 84

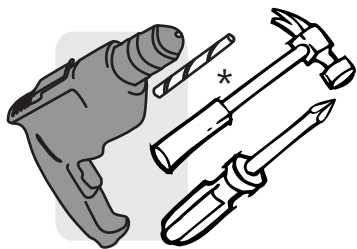

\*(Herramientas NO incluidas)/  
(Tools not included)

- Taladro/ Drill
- Broca de muro de 5/16"/ 5/16" Drill bit.
- Destornillador de estrella/ Star Screwdriver
- Destornillador de pala/ Flat Screwdriver

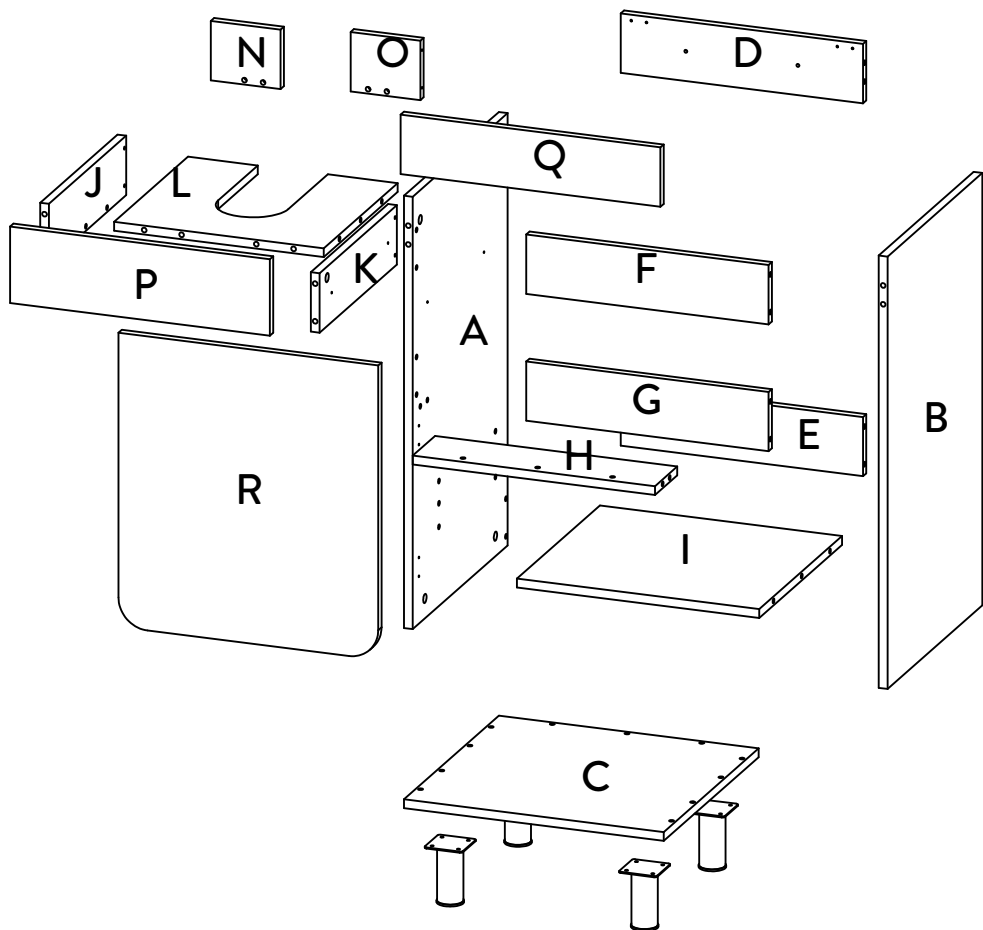



Leer las recomendaciones de ensamble antes de comenzar con el armado del mueble /  
Read the assembly instructions before starting the assemble of the cabinet.

1

Se recomienda armar el mueble sobre la caja o sobre una superficie lisa para no rayarlo; y con la ayuda de otra persona / It's recommended to assemble the cabinet above the box or on a flat surface to not scratch it and with the help from another person

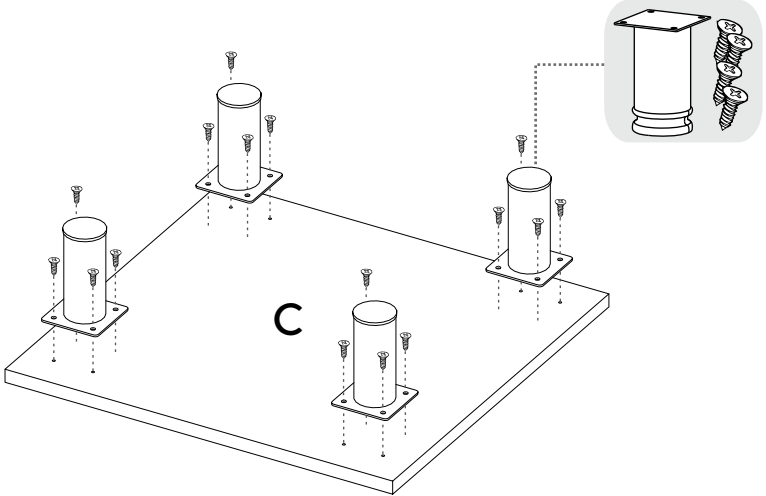

  
VOLTEAR  
TURN OVER

2

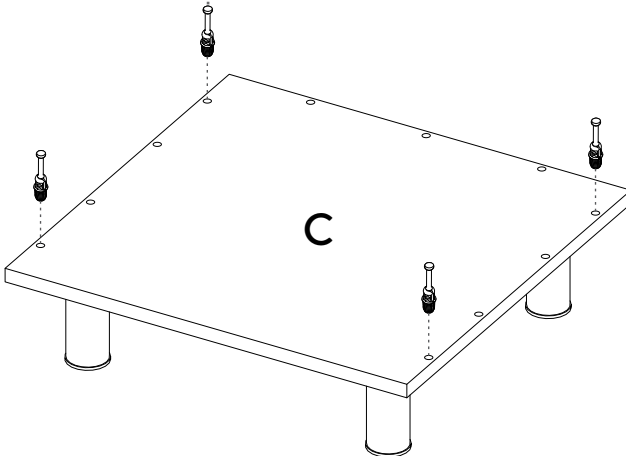

3



PARA PONER RIEL EN LATERAL DEL MUEBLE/  
TO PUT THE DRAWER SLIDE ON THE SIDE OF THE FURNITURE:

Revisar que el **tope plástico** del riel quede en la **PARTE TRASERA**/  
*The plastic stop should be placed on the rear.*

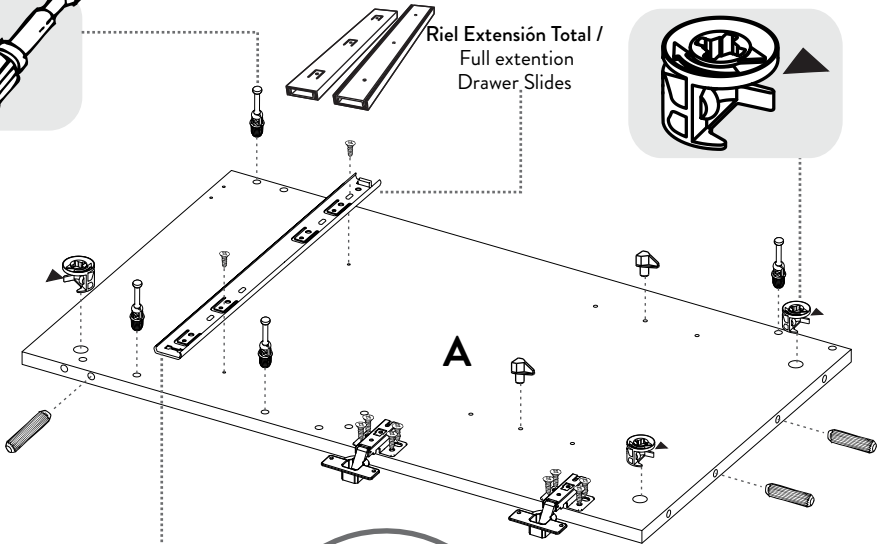
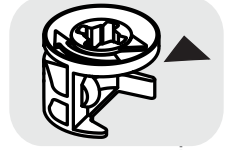
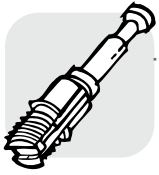

4

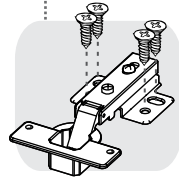
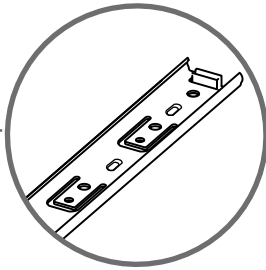

Bisagra parche/  
Full overlay hinge

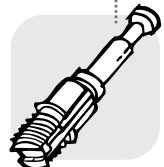
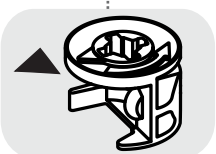
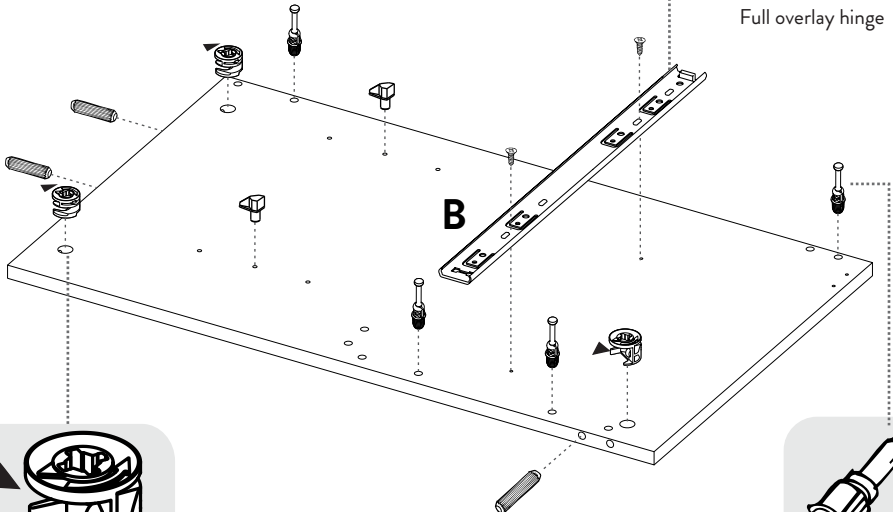



5

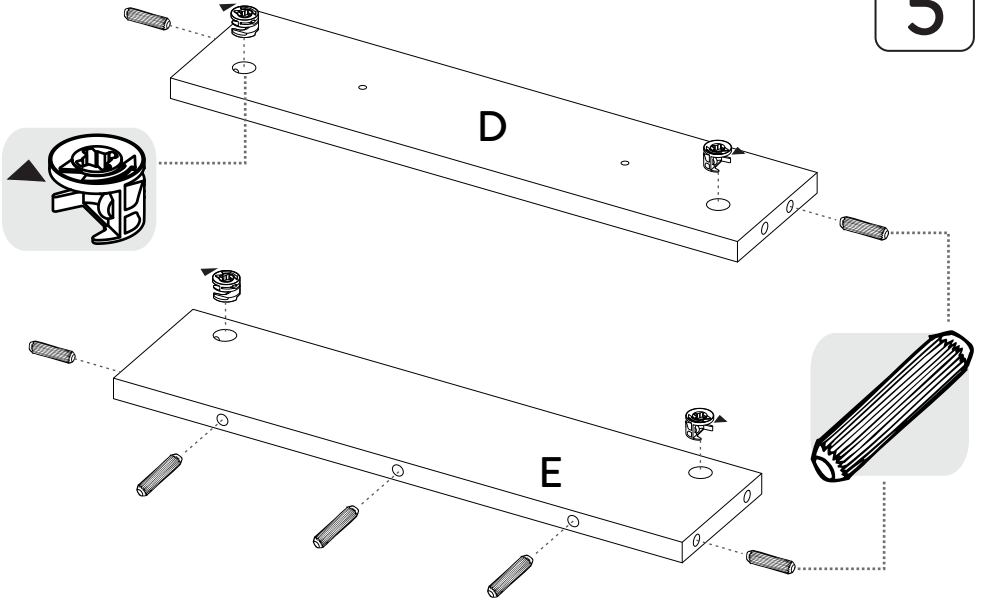

6

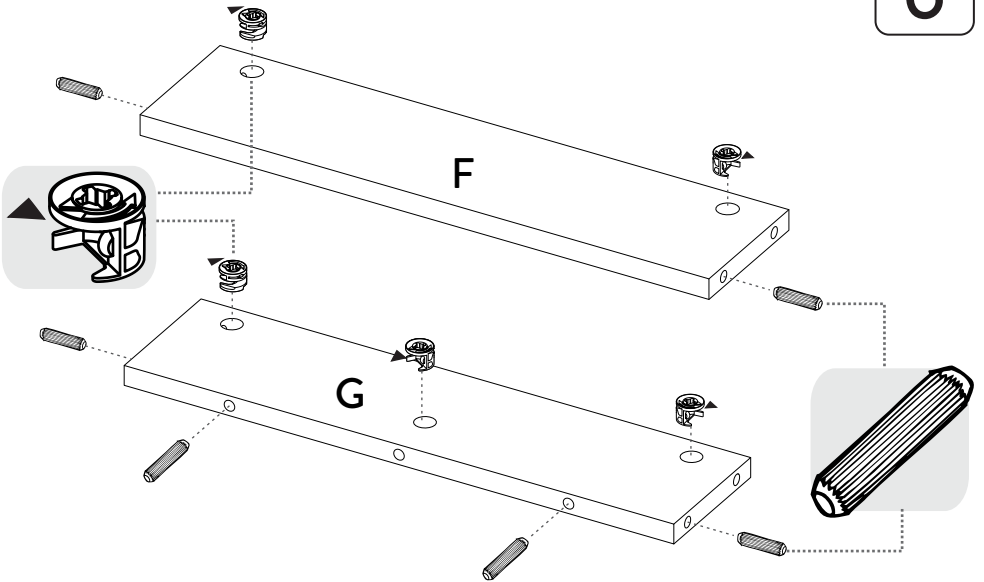

7

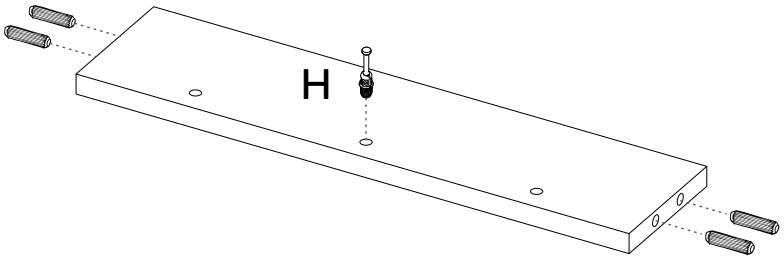

8

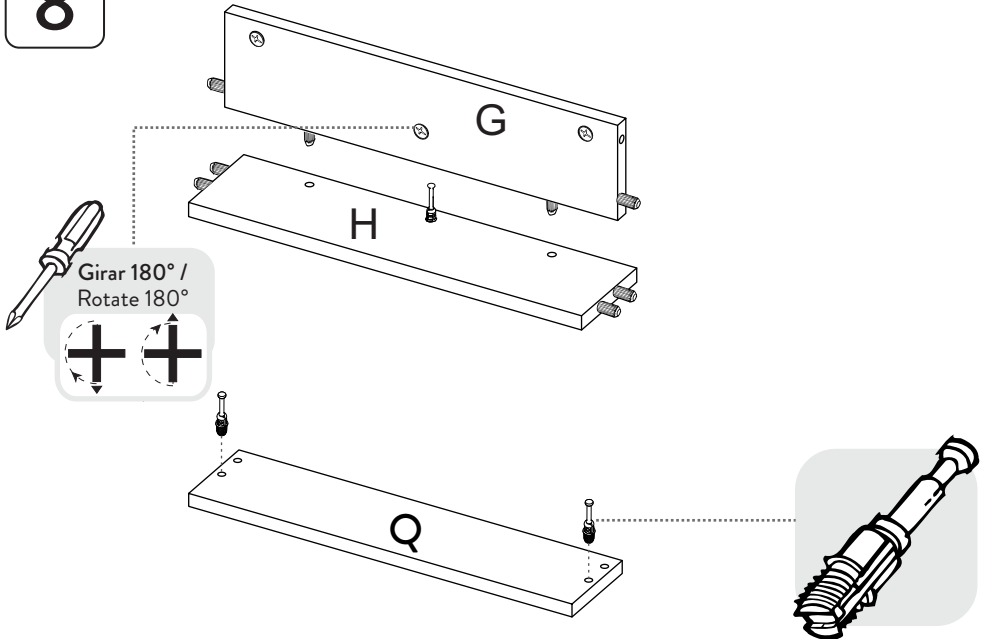

9

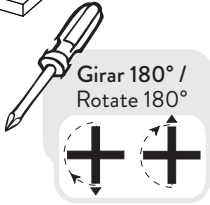
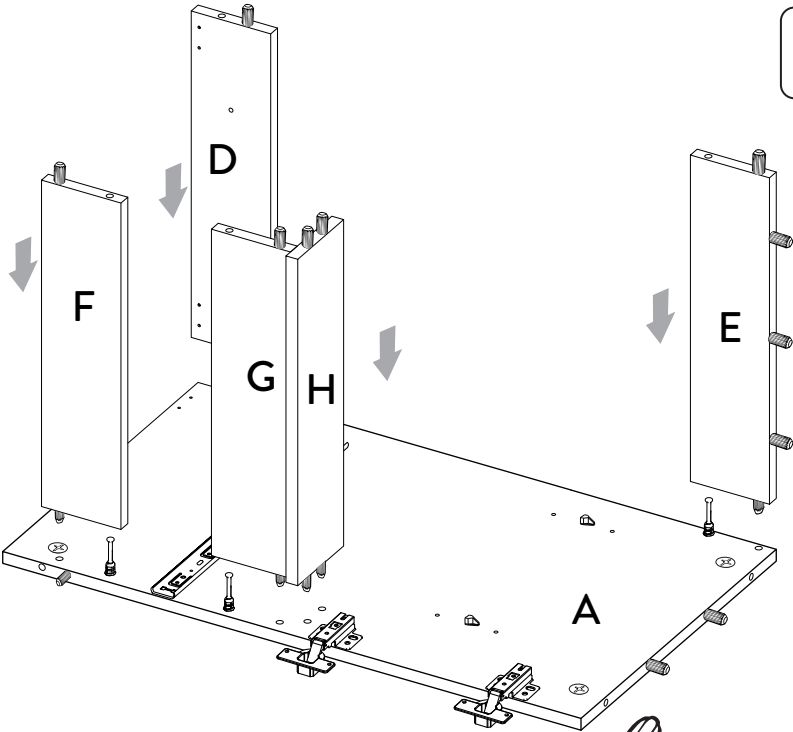

10

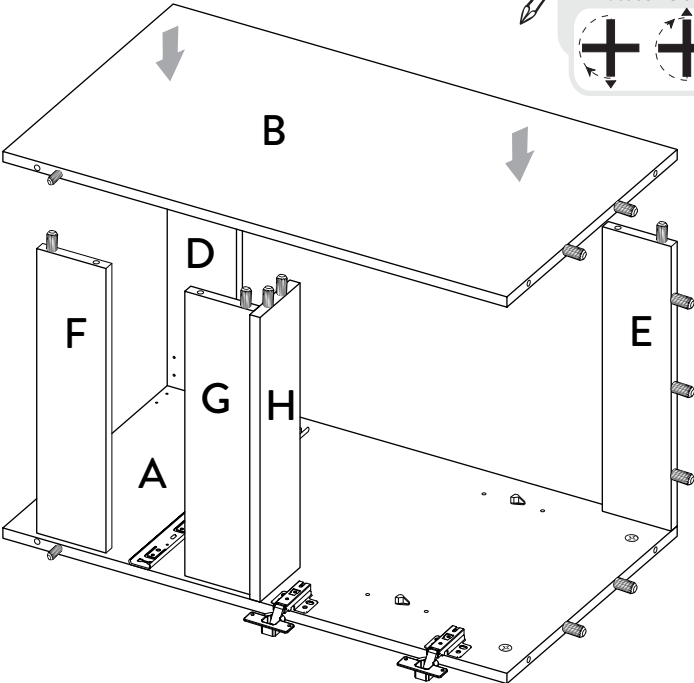

11

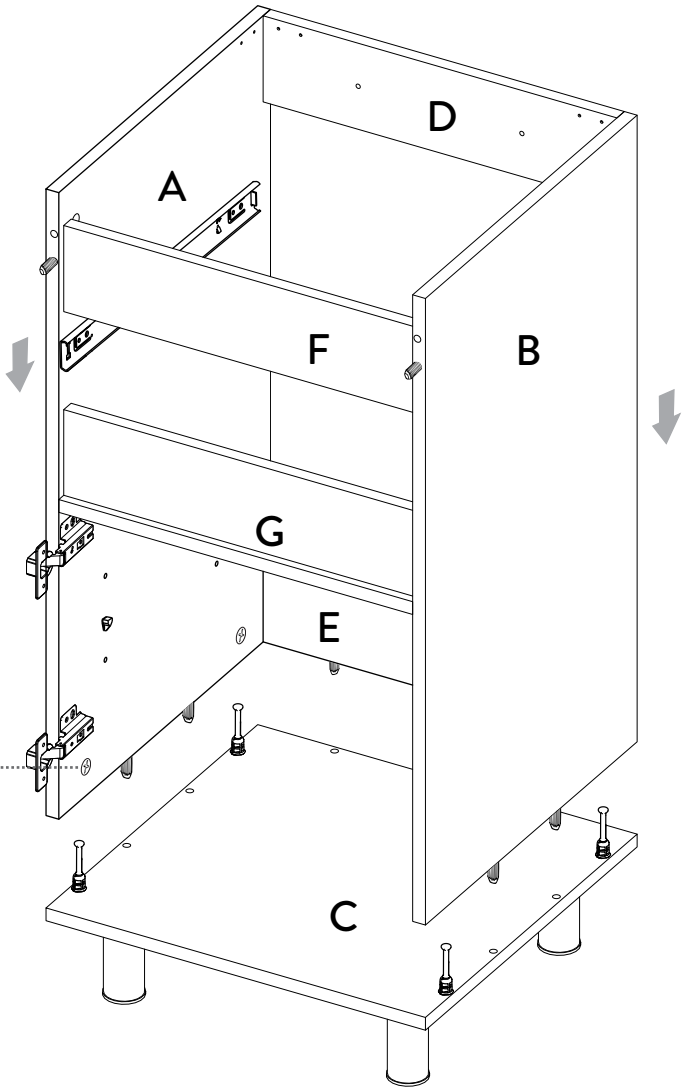

Girar 180° /  
Rotate 180°



12



Girar 180° /  
Rotate 180°

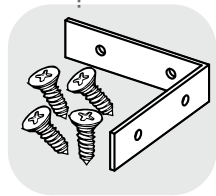
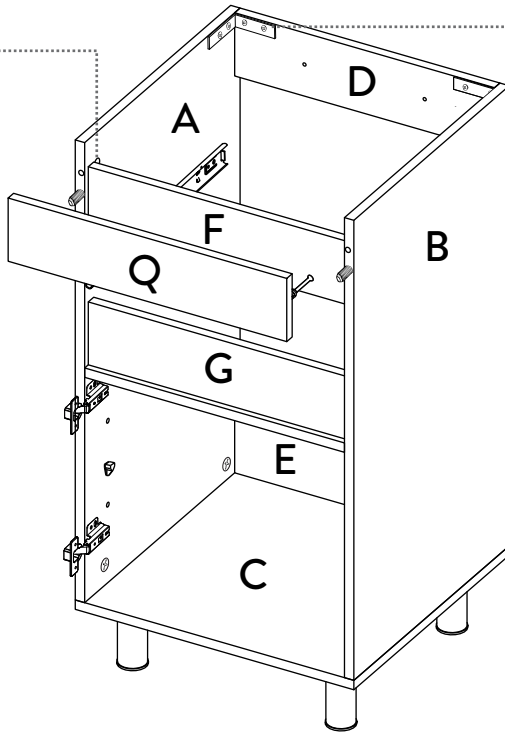

Platina en L/  
Angle Brackets

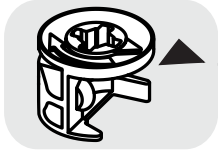

13

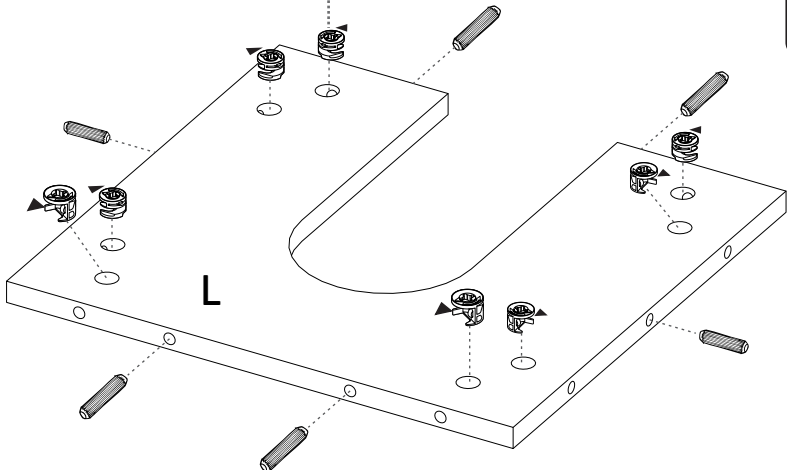

14



**PARA PONER RIEL EN LATERAL DEL CAJÓN/**

When placing the slide on the side of the drawer:

Revisar que el tope metálico del riel quede en la PARTE DELANTERA/

The metallic stop should be placed on the front.

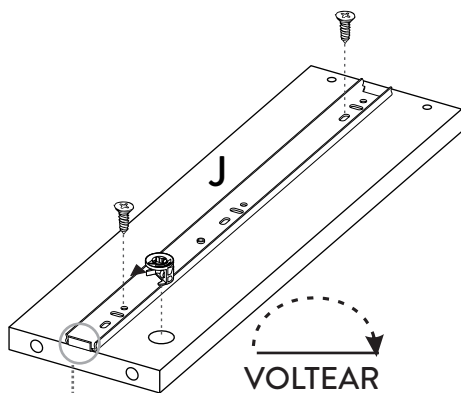

**VOLTEAR  
TURN OVER**

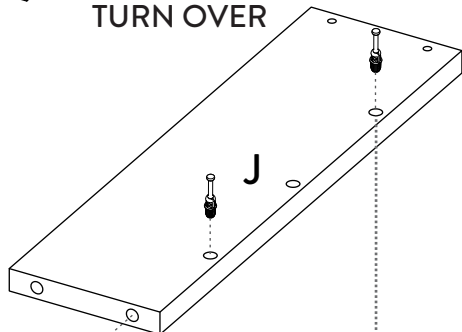

15



**PARA PONER RIEL EN LATERAL DEL CAJÓN/**

When placing the slide on the side of the drawer:

Revisar que el tope metálico del riel quede en la PARTE DELANTERA/

The metallic stop should be placed on the front.

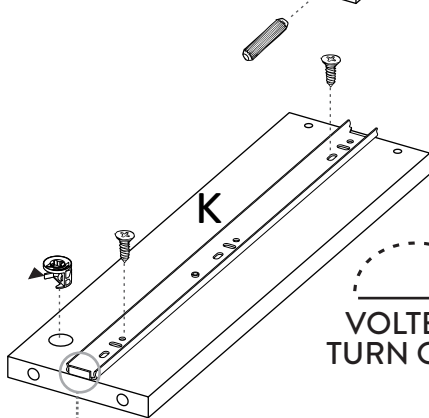

**VOLTEAR  
TURN OVER**

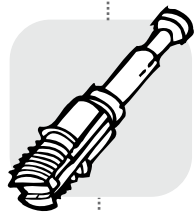
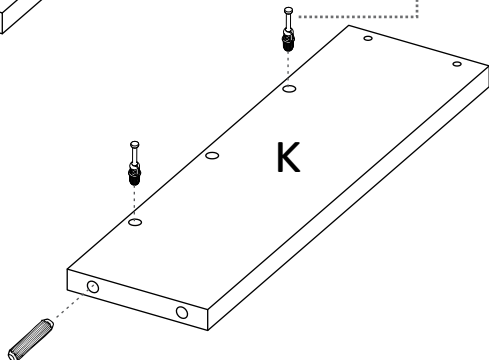

16

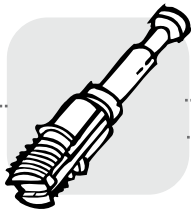
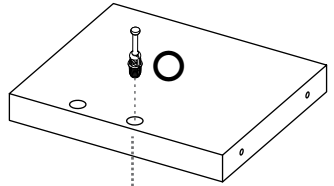
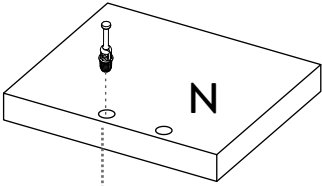

17

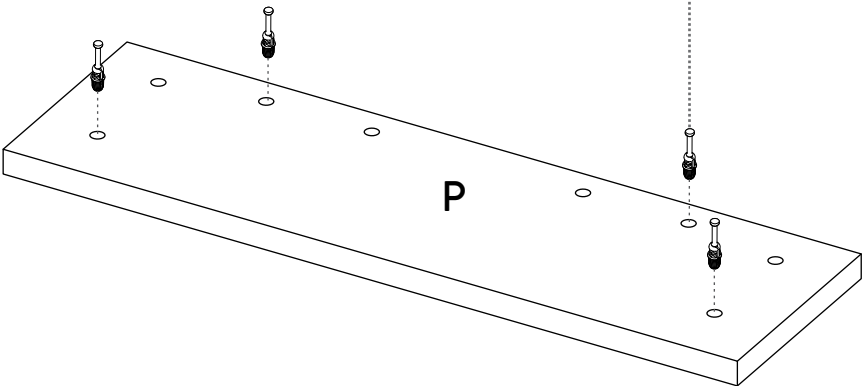

18

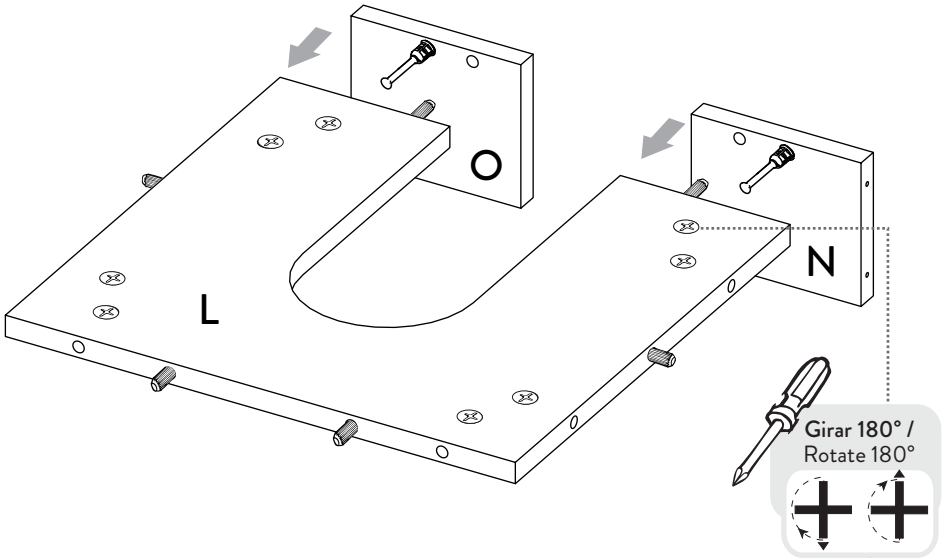

19

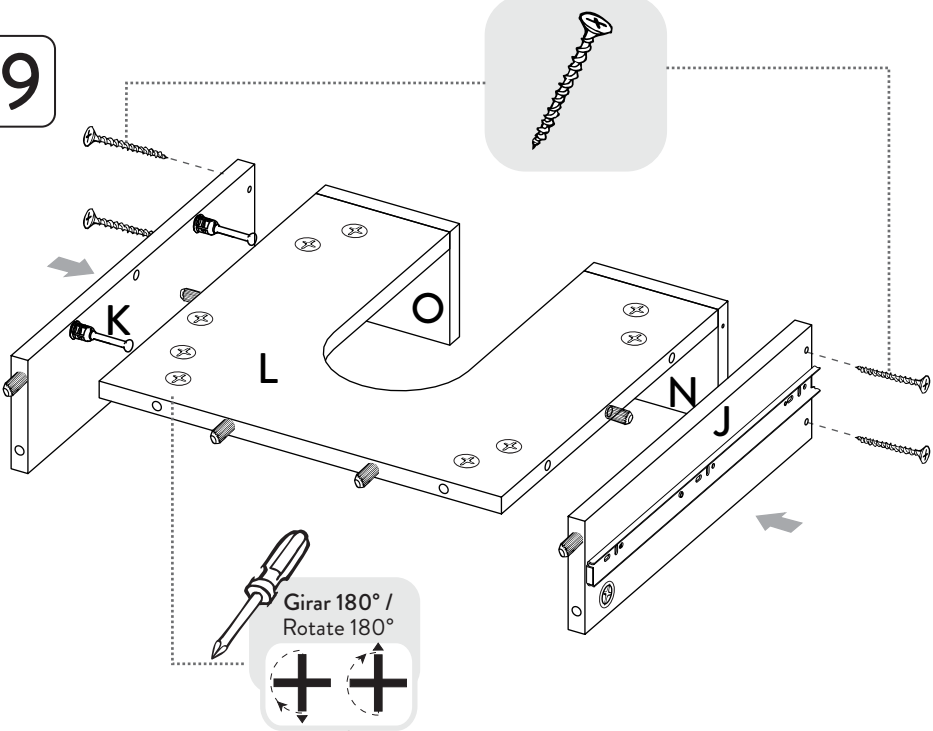



20



Girar 180° /  
Rotate 180°

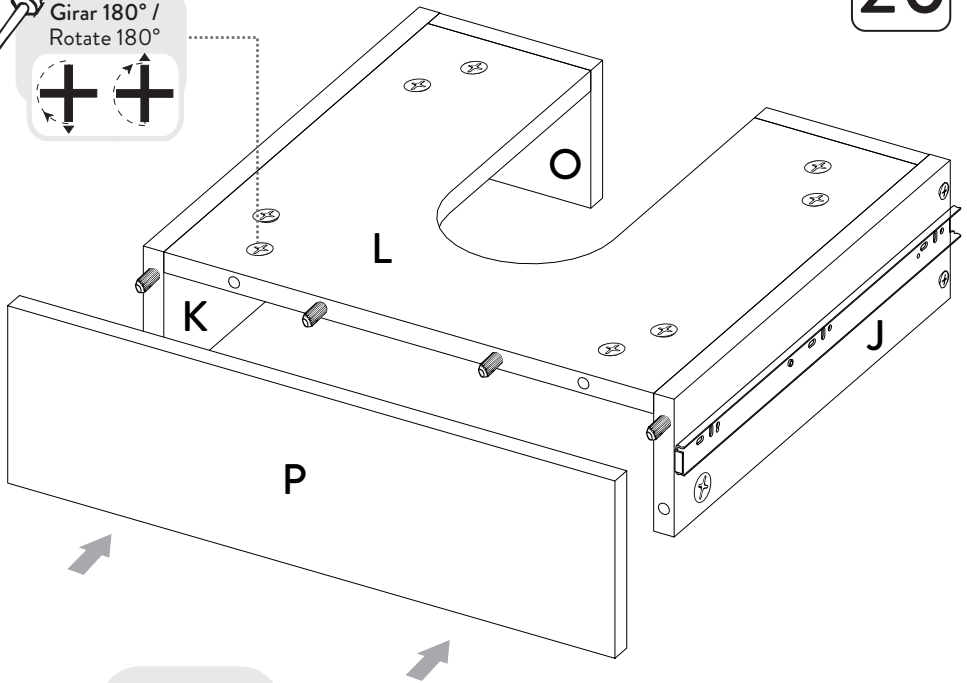

21

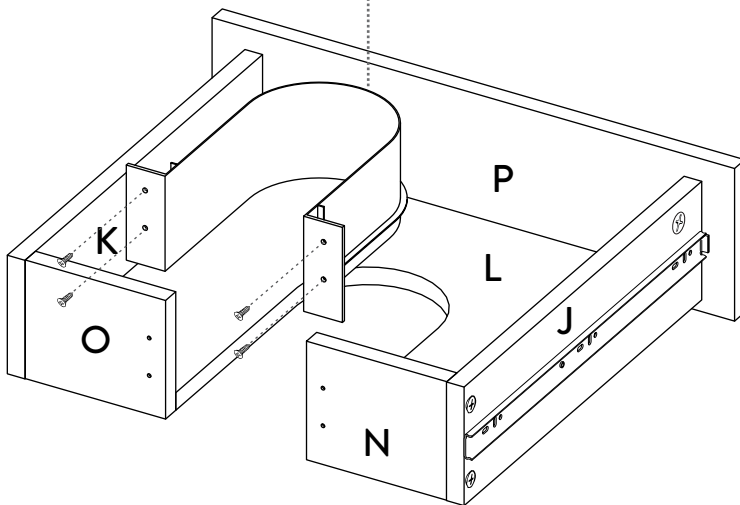
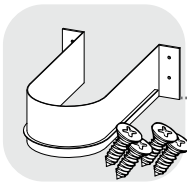

# 22



## PARA INSTALAR A PARED WALL INSTALLATION

\*Herramientas  
NO incluidas/  
Tools not  
included

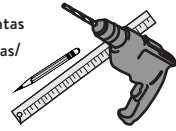

Utilizar una broca  
de 5/16" para hacer  
las perforaciones  
en el muro/  
Use a 5/16" drill bit  
to drill the wall.



Tornillo 2" +  
Chazo Mariposa/  
Wall Anchor

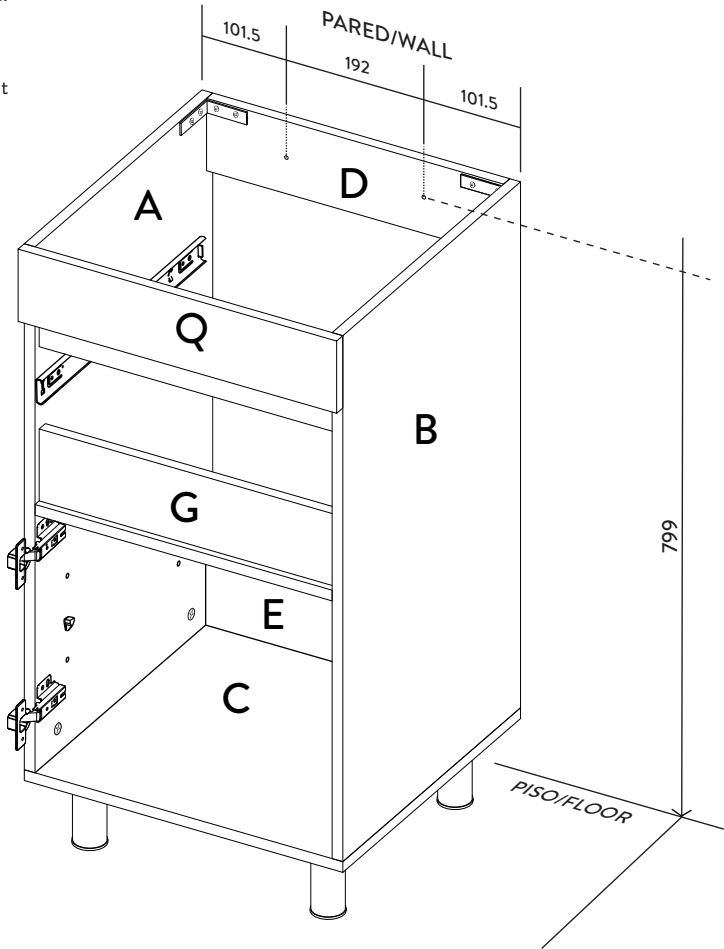

**IMPORTANTE**

Medir y marcar las distancias, como muestra la figura, recuerde que las perforaciones deben estar alineadas / Take measures and distances, as shown in the figure, remember that the holes must be aligned.

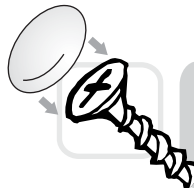

\*Medidas en milímetros /  
Measured in millimeters

No olvide poner las tapas adhesivas en donde quedan visibles/ Don't forget to stick the cover caps where visible